

The Simulation of SASAR11 X-Band Imaging Radar using Pulse Compression

Prepared by:

Malesela Lawrence Sathekge
Fourth-Year Electrical Engineering Student
University of Cape Town

This report is submitted to the Department of Electrical Engineering in partial
fulfilment of the degree of Bachelor of Science in Electrical Engineering

30th October 2004



Declaration

I declare that this report is my own work. It is being submitted to the University of Cape Town in partial fulfilment of the degree of Bachelor of Science in Electrical Engineering.

Signature of the Author.....

Cape Town

19 October 2004

Abstract

Synthetic Aperture radar uses long range propagation characteristics of radar signals and the complex information processing capability of modern digital electronics to provide high resolution imaging. It can provide high-resolution images from platform operating at long ranges, despite severe weather conditions. The University of Cape Town (RRSG) group are currently building a SASARII radar. This report is based on the simulation of the SASARII X-Band Imaging radar. The simulation uses chirp pulse as base-band signal. The report describes all the signal processing techniques of the SASARII X-Band Imaging radar, component limitations on the system resolution in particular the noise and non-linearities they generate. ADC limitations on the system resolutions are also addressed.

In this project the signal had to be processed, integrated i.e. adding many pulses like a real radar and demodulated down to baseband using digital demodulation technique because modern radar demodulation techniques employ this method, however time constraints could not permit neither pulse integration nor digital demodulation of the signal down to baseband to take place. The investigations that were to be carried out on the simulation of the SASARII X-Band Imaging radar were based on the work that has already been established by Masters students.

Acknowledgements

I would like to thank my supervisor, professor Michael Inggs, for his comments and guidance during this thesis project. He helped me to work hard. I would like to thank Richard Lord for helping me with referencing.

I would like to thank my family for encouraging me and being with me all the time. A Deep sense of graditute goes to all my best friends, thank you.



Contents

1	Introduction	12
1.1	Terms of Reference	12
1.2	Plan of Development	14
2	Background Information	15
2.1	Background of the Project	15
2.2	Overview of Simulation	15
2.3	The transmitter	16
2.3.1	The Generation of the chirp signal to IF1	16
2.3.2	The IF2 Stage	16
2.3.3	Last Upconversion Stage at RF	16
2.3.4	Amplification	17
2.4	The Receiver	17
2.4.1	The RF stage	17
2.4.2	Receiver Downconversion Stages	17
2.5	The ADC	17
2.6	Pulse Compression	17
2.7	Demodulation	18
3	Transceiver Simulation Design	19
3.1	Introduction	19
3.2	The transmitter	19
3.2.1	Basic theory and Generation of the Baseband Chirp Pulse	19



3.2.2	The IF stages of the Transmitter	20
3.2.3	The transmitted power budget	22
3.3	The Receiver	23
3.3.1	Downconversion Stages at the Receiver	23
3.4	Receiver Power Budget	23
3.5	Mixers, Filters, Amplifiers, Combiners and Splitters	26
3.5.1	Mixers	26
3.5.2	Filters	27
3.5.3	Amplifiers, Combiners and Splitters	28
3.6	System Resolution	28
3.7	ADC Considerations	28
3.8	Pulse compression	29
3.9	Pulse integration	29
3.10	Demodulation	30
3.11	Summary	30
3.11.1	Transmitter	31
3.11.2	Receiver	31
4	Testing of the System	33
4.1	Introduction	33
4.2	Filter Testing	33
4.2.1	Filter type	33
4.2.2	Test Procedure	33
4.2.3	Test Results	34
4.3	Non-Linearity Test	35
4.3.1	Test Procedures	35
4.3.2	Test Results	36
4.4	Noise level test	36
4.4.1	Test Procedure	36
4.4.2	Test Results	36



4.5	Power Return Test	37
4.5.1	Test procedures	37
4.5.2	Test Results	38
4.6	Radar Resolution	39
4.7	Summary	40
4.8	Discussion and Analysis	40
4.8.1	Filter test Results	40
4.8.2	Non-linearity	41
4.9	Power return test	42
4.10	Demodulation and Pulse Integration	43
5	Conclusions and Recommendations	44
5.1	Conclusions	44
5.2	Recommendations	44
	Bibliography	56



List of Figures

2.1	A block diagram showing all stages of the chirp radar simulation	16
3.1	Time and frequency I/Q components of the chirp pulse at baseband	20
3.2	Time and frequency domain I/Q components of the chirp at IF1	21
3.3	Complex chirp at IF1	21
3.4	The transmitter power simulation with components losses and power levels	22
3.5	The receiver component losses and power levels	24
3.6	The receiver block diagram	25
3.7	Data for calculation of the receiver worst noise figure	26
3.8	Harmonic inter-modulation products at IF1	27
3.9	Diagram comparing Group Delay of two filters	28
3.10	A block diagram of a conventional radar receiver demodulation	30
3.11	A block diagram of the modern radar receiver demodulation	30
4.1	5th order Butterworth filter group delay	34
4.2	9th order Butterworth filter group delay	34
4.3	9th order Chebyshev filter group delay	35
4.4	9th order Bessel filter group delay	35
4.5	Mixer intermodulation products	36
4.6	Transmitter noise levels	37
4.7	Power Budget for Corner Reflector	38
4.8	5th order Butterworth filter group delay	41
4.9	Mixer harmonics showing non-linearity contribution	42



5.1	The transmitter System View set-up	48
5.2	First section of the receiver System View set-up	49
5.3	Section of the receiver System View set-up	50
5.4	Output from receiver to the ADC	50
5.5	The signal at the transmission point	51
5.6	5th order Butterworth filter group delay	51
5.7	9th order Bessel filter group delay	52
5.8	The real match filtered signal	53
5.9	Analytic Signal	53
5.10	Matlab version of the signal at 2nd IF output	54
5.11	Matlab output of the receiver at 158MHz	54
5.12	The match filter output	55



List of Tables

3.1	Data for calculation of the receiver parameters	25
3.2	Mixer harmonics at IF1 with LO=158MHz and RF=0MHz	26
3.3	Matlab values in a pulse compressed signal	29
4.1	The ground range profile used for testing performance of the designed radar	38
4.2	Results obtained by testing the simulation with near, middle, far swath and corner reflector targets	38
4.3	Results obtained by testing the simulation with near, middle, far swath and corner reflector targets	43

List of Symbols

c	Time and frequency I and Q components of the chirp pulse at baseband
σ	Radar cross sectional area of target
f_o	Carrier frequency in [Hz]
F	Noise figure
K	Chirp rate
kW	kilo-Watt. Unit for measuring power
m	metres
t	Time [s]
T	Pulse length [s]
V	Voltage [V]
V_q	The ADC quantisation voltage [V]
V_{RF}	The RF voltage of the signal [V]
V_{bb}	The baseband voltage of the transmitted signal [V]
V_{IX}	The analytic representation of the voltage signal [V]
W	Watt. Unit for measuring power smaller than kW by a factor of a 1000

Nomenclature

ADC	Analog to Digital Converter
Baseband	The low range frequency of the signal normally to be upconverted to radio frequency
Chirp	A pulse modulation method used for pulse compression. The frequency of each pulse is varied at a constant rate through the length of the pulse
DAC	Digital to Analogue Converter
DPG	Digital Pulse Generator
I	In-Phase chirp component
IF	Intermediate Frequency
LNA	Low Noise Amplifier
LO	Local Oscillator
LSB	List Significant Bit of an ADC
PRF	Pulse Repetition Frequency
Power return	The power that is received at the receiver when the signal bounces off a target
PRF	Pulse Repetition Frequency
Q	Quadrature component of the chirp
Radar	Radio Detection and Ranging
RCS	Radar Cross-Sectional Area. An area of the target that intercepts the transmitted electromagnetic flux.
Range	The radial distance from a radar to a target
RF	Radio Frequency
RRSG	Radar Remote Sensing Group
SAR	Synthetic Aperture Radar
SASARII	South African Synthetic Aperture Radar
STC	Sensitivity Time Control
STD	Standard Deviation
Swath	The area on earth covered by the antenna signal
Target	Any object that interferes with electromagnetic radiation

Chapter 1

Introduction

This report describes the simulation of the SASARII X-Band imaging radar using Pulse Compression (Chirp Pulse) to investigate the effect of component limitations in the transceiver chain, their effect on the resolution and sensitivity of the system. For the purpose of this report the following investigation in particular will be carried out:

- System filters (upconversion and downconversion)
- System noise
- System non-linearity
- System losses (filters, combiners, splitters, etc.)
- ADC quantisation level (full scale and number of bits)

The target (the received signal at the receiver) will be a delta function i.e. a delayed version of the transmitted signal.. The results of this simulation shall be used for comparison with the Pulsed and Stepped Frequency radar simulations. All the relevant information required for the purpose of these report were gathered from several relevant books [?, ?, ?, ?] and the user requirement information provided by the project supervisor [?] .

1.1 Terms of Reference

The following user requirements were agreed upon with [?] for the purpose of this project:

The transmitter

- The DAC shall output two channels at maximum power of +10dBm each. Each baseband channel shall have bandwidth of 50MHz.
- The system shall have two IF stages at 158MHz and 1300 MHz and a RF stage at 9300 MHz.
- System filtering will consist of filters of different types for investigation of their effects on the system's resolution.
- The transmitted peak power level shall be 3.5 kW.
- The system shall have a pulse repetition frequency (PRF) of 3kHz and pulse length of $5\mu s$.
- The DAC and ADC shall be clocked with 150MHz and 210MHz respectively. The jitter must not exceed $6ps$.

The receiver

- The receiver system shall have a dual - stage downconversion stage from RF of 9300MHz, two IF stages at 1300MHz and 158MHz
- Filtering will consist of different filters for investigation of their effects on the system's resolution
- The effect of Thermal noise on the system will be investigated
- The transmitted power and carrier frequency are set considering the operational parameters of the available power amplifier.
- The transmitted carrier frequency is set to 9.3 GHz .
- Maximum number of range samples of 8192.
- Maximum instantaneous receiver bandwidth of the system should be 100 MHz.
- System filtering should ensure maximum phase linearity.
- An analogue-to-digital converter (ADC) with sample rate of 210 MHz and a minimum of 8 bits and with maximum input power of 13 dBm should be used to digitise the received signal.

The Software used for this simulation is System View(by Elanix)

1.2 Plan of Development

The arrangement of this report is as follows:

Chapter 2: Background Information

This chapter introduces the background of this report. The beginning of this chapter introduces the reasons for the need of the simulation of the SASARII X-Band imaging radar using Chirp Pulse as Baseband Signal. It continues with a brief description of all the transceiver units and also provide and overview of the simulation. It finishes by clearly giving summary of the simulation.

Chapter 3: Transceiver Simulation Design

In this chapter the transceiver is described theoretically. The chapter begins with a theoretical description of the Baseband Chirp Pulse. It continues with a theoretical description of all the stages of the transmitter and the receiver. It gives the reader a full picture of what the Chirp Pulse is and how it is processed through all the transceiver units. It finishes by giving a brief overview on the ADC considerations and further describe pulse integration on the system's output, demodulation technique used as well as summary of all theoretical requirements for the simulation.

Chapter 4: Testing of the System

Testing of the system is described in this chapter. It first introduces the reader to main methods of performing tests, the observations that came out in the simulation in particular the observations are made in relation to the main investigations that were to be carried out for the purpose of this report. All the necessary theoretical description of important radar concepts needed to assess the performance of this chirp radar simulation are outlined in this chapter. All the types, procedures and methods for testing used for each test are described in detail. This chapter serves as the bases upon which the whole simulation could be checked and analysed. It provides the results for every type of test performed according to terms of reference. The end of the chapter discusses these results.

Chapter 5: Conclusions and Recommendations

This chapter make final conclusions and recommendations for future work on this subject based on the observations, analysis and discussion of the results obtained.

Chapter 2

Background Information

2.1 Background of the Project

In 2004 UCT RRSg (*Radar and Remote Sensing Group*) were in progress of integrating SASARII (**South African Synthetic Aperture Radar**) X-Band imaging radar. This particular radar operate in the frequency range of 8 - 12 GHz (3cm wavelength). To asses its performance, the radar had to be tested using different kinds of waveforms. The waveforms are:

- Pulsed Radar
- Stepped Frequency Radar
- Chirp Radar

This simulation is carried out as part of the assessment of this radar. A pulsed radar transmits all components of its spectrum with each pulse, and resolves targets in the fast time delay dimension. Stepped frequency systems transmits its spectrum in a sequence of steps, and converts the signals received in the frequency domain to time domain. Pulsed Compression (Chirp Pulse) allows a long pulsed radar to transmit a wide bandwidth waveform and achieve high resolution by means of pulse compression (cross correlation with a replica of the transmitted waveform) [?].

2.2 Overview of Simulation

The simulation of the SASARII X-Band Imaging radar can best be described by the block diagram on Figure 2.1. The diagram shows a delay of the transmitted signal as mentioned in chapter 1 that it is for the purpose of this report to receive a delayed version of the transmitted signal at the receiver so

that a real radar situation could be simulated since the time it takes for the transmitted signal to travel to a target situated at some distance R is given by equation in [?, pg 17].

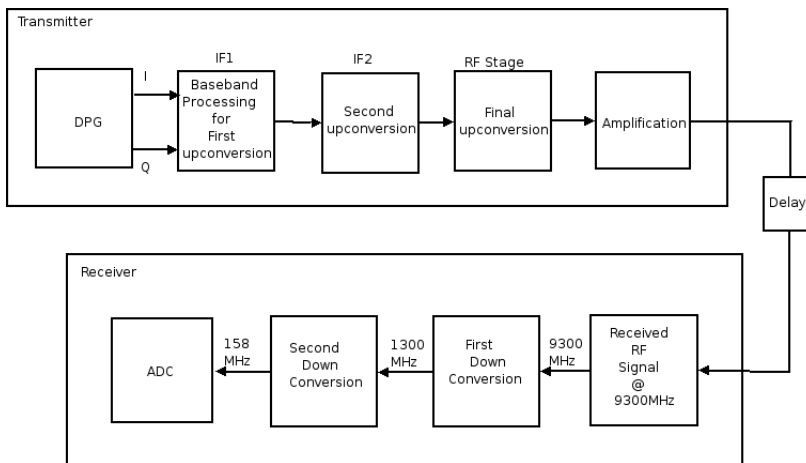

Figure 2.1: A block diagram showing all stages of the chirp radar simulation

2.3 The transmitter

The transmitter takes the low power base-band signal to high power RF signal and it comprises LO, mixers, filters and amplifiers.

2.3.1 The Generation of the chirp signal to IF1

The baseband information shall be two quadrature signals output by the DPG with a real bandwidth of 50MHz. They will be combined to produce a 100MHz complex chirp signal and mixed with a 158MHz LO signal to be upconverted to the IF1 stage at 158MHz.

2.3.2 The IF2 Stage

The second IF is chosen to be at 1300MHz as stated in terms of reference.

2.3.3 Last Upconversion Stage at RF

The last upconversion stage is at 9300MHz. The LO will be sitting at 8000MHz. After this stage the signal will be ready for transmitting.

2.3.4 Amplification

The required power level of the signal before transmission shall be 3.5kW as stated in terms of reference. The power amplifier at this stage will be used to achieve the required power level because the signal suffer losses due to RF components as it propagates through all the stages of the transmitter chain.

2.4 The Receiver

The receiver too consists of all RF components i.e. mixers, LO, Filters and amplifiers.

2.4.1 The RF stage

At this stage the signal received at the receiver is a delayed version of the transmitted signal. The incoming RF signal is propagating at 9300MHz.

2.4.2 Receiver Downconversion Stages

At this stage the received RF signal is mixed with a LO at frequency of 8000MHz. The second downconversion will have a LO with a frequency of 1142MHz. The received signal sitting at 158MHz shall then be fed to an ADC for digital processing.

2.5 The ADC

A 210MHz clock signal is generated to clock the ADC in order to convert the signal from analog to digital form.

2.6 Pulse Compression

To increase the signal-to-noise ratio the signal is passed through a match filter to get the peak signal-to-noise ratio.



2.7 Demodulation

Demodulation of the signal into I/Q baseband signals is performed digitally as stated by the project supervisor [?]. The signal shall be demodulated down to baseband at 50MHz. Modern radar demodulation techniques are employed for demodulation.

Chapter 3

Transceiver Simulation Design

3.1 Introduction

In this chapter the transceiver is described theoretically. The chapter begins with a theoretical description of the Baseband signal. It continues with a theoretical description of all the stages of the transmitter and the receiver. It gives the reader a full picture of what the Chirp Pulse is and how it is processed through all the transceiver units. It finishes by giving a brief overview on the ADC considerations and further describe pulse integration on the system's output, demodulation technique used as well as summary of all theoretical requirements for the simulation.

3.2 The transmitter

The requirements for the design of the chirp radar transceiver are drawn in terms of reference[?].

3.2.1 Basic theory and Generation of the Baseband Chirp Pulse

The RF chirp signal looks as shown in the equation:

$$V_{RF}(t) = \text{rect}\left(\frac{t}{T}\right) \cos\left[2\pi\left(f_0 t + \frac{1}{2} K t^2\right)\right] \quad (3.1)$$

This signal can be represented analytically as,

$$V_{TX}(t) = \text{rect}\left(\frac{t}{T}\right) \exp^{j2\pi\left[f_0 t + \frac{1}{2} K t^2\right]} \quad (3.2)$$

Baseband Representation of the signal is as shown:

$$V_{bb}(t) = \text{rect}\left(\frac{t}{T}\right) \exp^{j2\pi\left(\frac{1}{2} K t^2\right)} \quad (3.3)$$

The mathematical validity of these equations can be found in [?, pg 35]. From the equations above it follows that the output of the baseband signal shall therefore be the two quadrature, analogue channels (I and Q), where $I = \cos(\pi Kt^2)$, $Q = \sin(\pi Kt^2)$ (both real, even signals) as specified in the terms of reference. K is known as the chirp rate ($K = \frac{B}{T}$ in Hz/s) and f_o is the carrier frequency.

The two chirp pulses vary linearly in frequency from -50 to 50MHz in a period of $5\mu s$ (T). These two quadrature signals have a bandwidth of 50Hz each. They will be combined and upconverted to form a complex chirp pulse of 100MHz bandwidth. The first IF stage is at 158MHz and this imply that a 158MHz LO signal will be required to make the upconversion process as stated in [?]. Figure 3.1 shows the system view simulation time and frequency domain I/Q components of the chirp pulse at baseband.

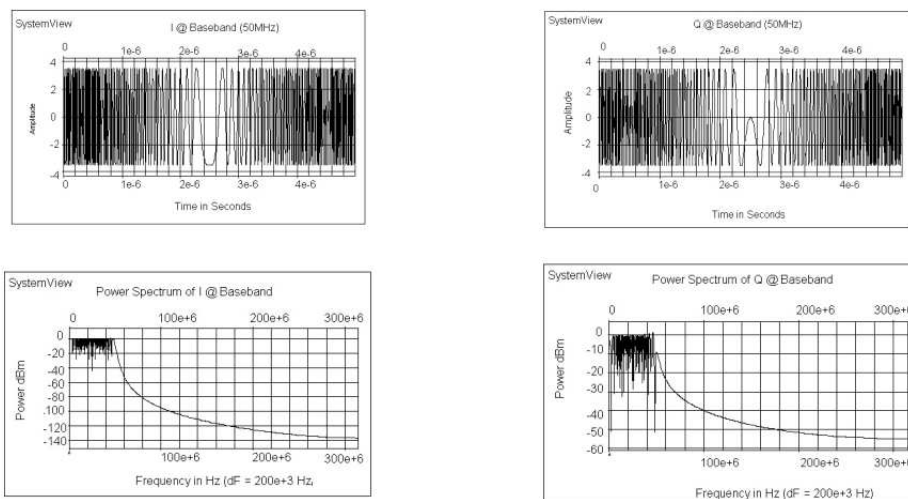

Figure 3.1: Time and frequency I/Q components of the chirp pulse at baseband

3.2.2 The IF stages of the Transmitter

In the IF1 stage the generated baseband chirp waveform is upconverted to the 158MHz LO frequency, followed by the second IF stages at 1300 MHz, and RF stage at 9300MHz and lastly amplification of the signal for transmission. Figure 3.2 shows the chirp at IF1 and evidence of the non-linearity and noise brought by mixers can be seen.

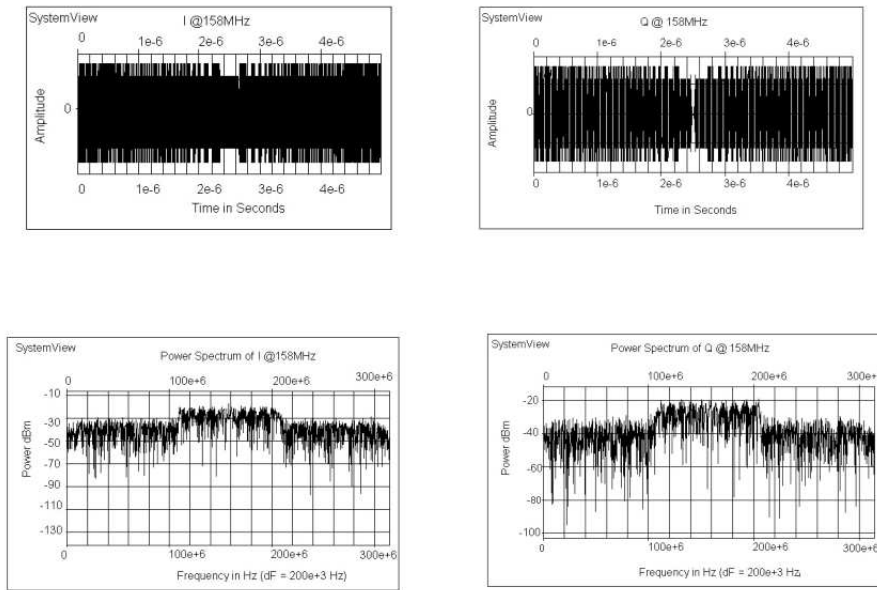

Figure 3.2: Time and frequency domain I/Q components of the chirp at IF1

Figure 3.3 shows the complex chirp at 158MHz. Component noise and non-linearity contributions can be clearly seen.

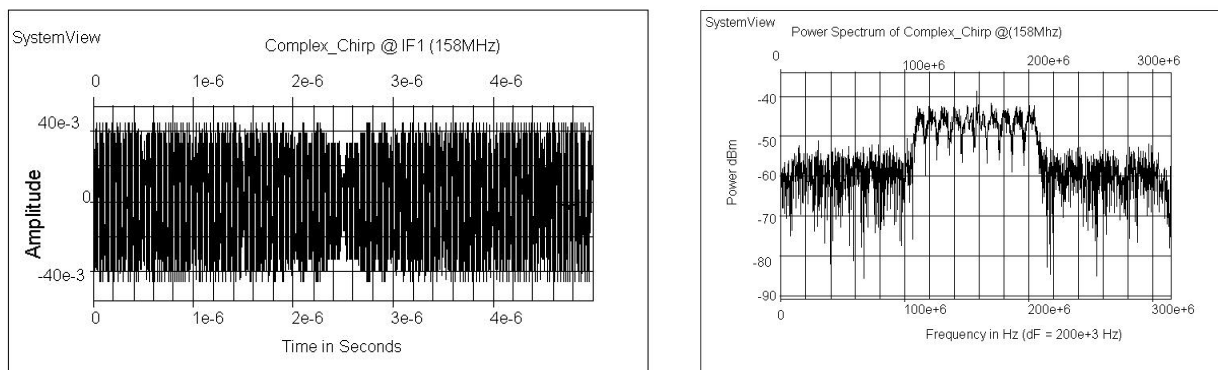

Figure 3.3: Complex chirp at IF1

3.2.3 The transmitted power budget

The required power level for transmission is 3.5kW. Figure 5.5 in **appendix B** shows the power at the output of the transmitter from system view. Therefore the power budget for the transmitter is achieved considering all the component limitations. *To reach this power all the noise from the RF components is considered by calculating the transmitter’s Noise Figure(F) as shown in [?, pgs (89-95)] based on the design in [?, pg 26].*

The cascaded system noise figure of the transmitter and the receiver is calculated based on equation 3.4 shown below. The theory for this calculation can be found in [?, pgs (89-93)] , *however with Sytem View signal-to-noise ratio is calculated by taking the ratios of the input and output of the receiver signal to noise signal, hence the receiver noise figure is calculated.*

$$F = \frac{S_i/N_i}{S_o/N_o} \tag{3.4}$$

Where S_i and N_i are the signal and noise at the input while S_o and N_o are signal and noise at the output of the system. The transmitting frequency is at 9300MHz as stated in terms of reference. The sampling rate must be atleast twice the highest frequency in the system according to Nyquist criteria. The System View sampling frequency was set to 37.2 G Hz i.e. four times the highest frequency of 9300MHz at RF . Figure 3.4 shows the power levels of the transmitter simulated from system view. **Figure 5.1 in appendix B shows the system view version of the transmitter.**

Figure 3.4: The transmitter power simulation with components losses and power levels

Token number	Loss [dB]	Gain	Name	Input Power [dB]	Output Power [dB]
1	7		Mixer	0	-8
2	7		Mixer	0	-8
11	0.3		Combiner	-16	-10
9	1.8		Filter loss	-10	-12
115		1	Amplifier	-12	-11
15	7		Mixer	-11	-20
73	2.1		Filter loss	-20	-21
18	5.5		Mixer	-21	-27
95	1.2		Filter loss	-27	-29
62		32	Amplifier	-29	3
85		32	Amplifier	3	35.5
96	0.8		Filter loss	35.5	35
Total	32.7	65			
	net gain	32.3			

3.3 The Receiver

All receiver design requirements were drawn out from [?].

3.3.1 Downconversion Stages at the Receiver

At this stage the received signal is a delayed version of the transmitted signal. In the receiver unit the signal received shall go through the downconversion stages i.e. from RF at 9300MHz to two IF stages at 1300MHz and 158MHz.

3.4 Receiver Power Budget

The output of the receiver shall be fed into an ADC for digitisation. In order to do this the correct power level is required and these facts are considered in receiver design:

- The minimum input signal power to the receiver is component noise while the maximum power is power returns (echoes) from different targets
- Power returns from targets used in [?] are used to set the receiver's minimum detectable signal. This is done by introducing appropriate path losses with the aid of an electronic attenuator in Sytem View. The signal is attenuated by an amount equal to the power returns from targets. Near, middle and far Swaths targets are used
- The output power fed into an ADC from the receiver is therefore limited by the ADC's maximum power input. This imply that targets outside the receiver's dynamic range cannot be resolved by the ADC.

Table 3.5 shows all losses and power levels of the receiver simulation in the design. The System View set-up showing component arrangement is shown in figure 5.2 and 5.3 in appendix B.

Figure 3.5: The receiver component losses and power levels

Token	Loss	Gain	Name	Input power [dBm]	Output power [dBm]
22	130		Attenuator (Path loss)	-65	
129			Filter	-65	
102	1			-65	-66
101		22	LNA	-66	-44
127	7.5		Mixer	-44	-51.5
106			Filter	-51.5	
21	1		Filter loss	-51.5	-52.5
99		29	Amplifier	-52.5	-23.5
108	7		Mixer	-23.5	-30.5
98		20	Amplifier	-30.5	-29
33			Filter	-29	
55	1		Filter loss	-29	-30
90	20		Attenuator	-30	-50
49	20		MGC	-50	-70
34		20	Amplifier	-70	-50
82		30	Amplifier	-55	-15
103		20	Amplifier	-15	5
43		1	Filter	5	
20	7		Filter loss	5	-2
			Net-gain = 77.5		

The whole receiver diagram could be summarised by a block diagram shown in figure 3.6. The diagram comes from [?] because the design is purely building on the design basis in [?].

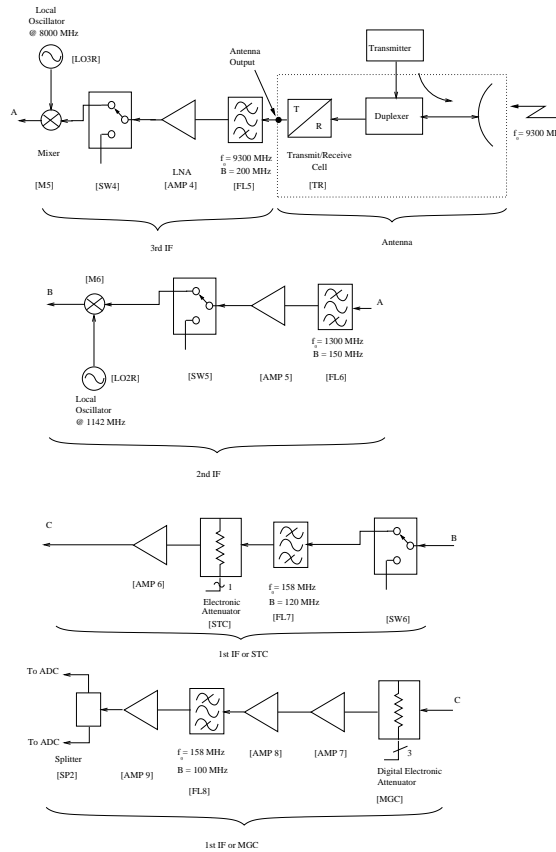

Figure 3.6: The receiver block diagram

The calculations for the receiver chain’s Noise Figure (F) is also done as shown in equation 3.4. The signal was attenuated to 130dB by an electronic attenuator in the simulation to a level were it was just below the noise level and the minimum detectable signal was calculated on the bases of the receiver’s minimum signal-to-noise ratio. The procedure for calculated minimum signal-to-noise ratio is done by taking the ratio of the signal’s maximum value to the standard deviation at the output of the receiver in System View. Table 3.1 shows the values obtained from System View. STD is the standard deviation while SNR_i and SNR_o are the input and output signal to noise ratio of the receiver.

Table 3.1: Data for calculation of the receiver parameters

Max input signal value [V]	Input STD [V]	Max output signal value [V]	Output STD [V]	SNR_i	SNR_o
$6.725e^1$	$2.767e^1$	$3.77e^2$	$2.488e^2$	2	1.5

The values in table 3.1 suggest that the minimum signal-to-noise ratio is 2 [dB]. The noise figure is therefore 2 [dB]. The noise figure is calculated using equation 3.4. The same procedure is carried out for calculation of the worst noise figure however the signal is not attenuated this time. Table 3.7 shows receiver data for calculation of the worst noise figure.

Figure 3.7: Data for calculation of the receiver worst noise figure

Max input signal value [V]	Input STD [V]	Max output signal value [V]	Output STD [V]	SNR_i	SNR_o
$3.77e^2$	62.833	$1.116e^2$	$7.22e^1$	6	1.5

The data in table 3.7 gives the worst noise figure of 6 [dB]. The calculation for the worst noise figure is calculated using equation 3.4.

3.5 Mixers, Filters, Amplifiers, Combiners and Splitters

All RF components used in this report start by following the design specifications used in [?] and [?] to design the transceiver chain and some tests are applied afterwards to observe the effects of different components on the system’s resolution.

3.5.1 Mixers

Mixers are three-port devices that uses non-linear elements to perform frequency conversion. There are losses and noise effects incurred by the mixer, so the purpose of this report will be to use mixers with specifications listed in [?, pg 28]. The output of the mixer is of the form $nLO \pm mRF$, m and n are integers. For the purpose of transmission the $LO+RF$ is the desired mixer output and in the receiver the mixers produce the $LO-RF$ components.

It should be noted that in the transmitter the lower side-band at the output of each mixer ($LO-RF$) is filtered and for the purpose of downconversion the upper side-band ($LO+RF$) is the filtered mixer output. all the unwanted (inter-modulation) products described in detail in [?, pgs ((100-101))] must be removed through filtering. Table 3.2 from [?, pg 20] shows the harmonics of the mixer at **IF1**.

Table 3.2: Mixer harmonics at IF1 with $LO=158MHz$ and $RF=0MHz$

n	m	$nLO+mRF$	$nLO-mRF$	Order
0	0,1,2,3...	0	0	1
1	0,1,2,3...	158	158	2
2	0,1,2,3...	316	316	3

The image frequencies are indisinduishable from the real desired frequency output and therefore if not filtered give rise to ambiguity in the radar’s resolution. Fig 3.8 also from [?, pg 21]shows how the desired signal is situated in relation to the LO and all inter-modulated products at IF1. Since it is

difficult to design a very sharp filter a realistic approach to the 5th order butterworth filter is considered i.e. to say that some inter-modulated products from these mixers will pass to the **IF2** stage. *The dark dotted line represent the response of a fifth order butterworth filter.* Mixers are be operated to their desired levels to avoid saturation.

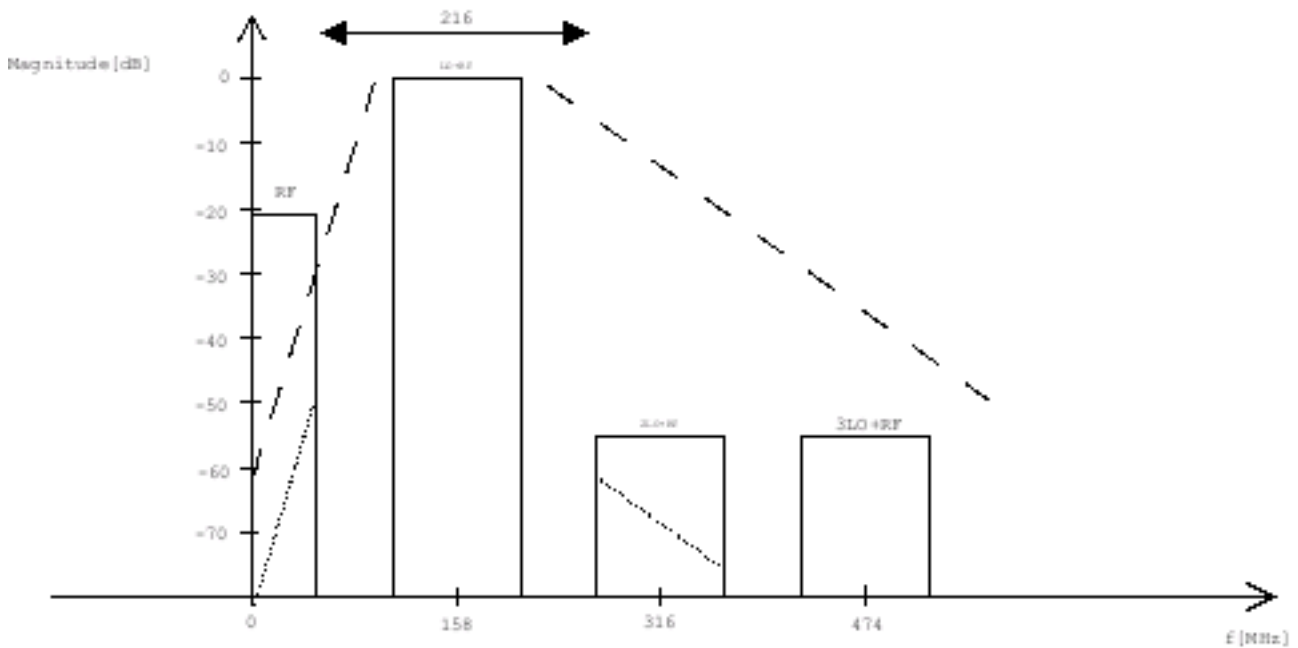

Figure 3.8: Harmonic inter-modulation products at IF1

3.5.2 Filters

The most significant properties of filters are its bandwidth, steepness of the transition band (roll-off) and group delay (delay time). These are significant factors contributing to the selection of a filter in wide-band systems. For a good filter choice a trade-off between its roll-off and bandwidth must be considered [?, pg 19]. This is because the increase in number of poles results in a steep roll-off. As the roll-off becomes sharp group delay increases as well. An increase in bandwidth decrease group delay.

For the purpose of this report 5th order butterworth filters will be used because they have a good trade-off between roll-off and group delay and they will later be compared with other filters in performance on the radar resolution. Generally we would like a filter with a sharper roll-off in order to reduce the unwanted side-bands power, however due to these two filter properties mentioned it is not possible to design such a filter. From previous work established by [?, pg 20] it was observed as shown in figure 3.9 how group delay varies with frequency of a particular filter.

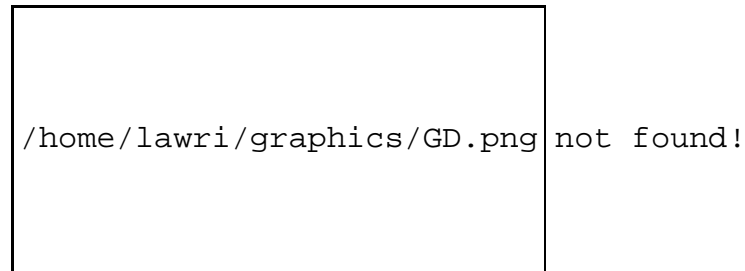

Figure 3.9: Diagram comparing Group Delay of two filters

3.5.3 Amplifiers, Combiners and Splitters

An amplifiers produce at its output an amplified or bigger version of the input signal. The amplifier too has its limitations, if operated beyond its limits an amplifier enter what is called compression points, or simply saturation and it become unstable. Therefore these consideration should be observed when using an amplifier. Combiners and splitters too have their own limitations as electric elements. The reader can find all theory of RF amplifiers in full detail in [?, pg 99].

3.6 System Resolution

It was mentioned in chapter 2 section 2.1 that Pulsed Compression (Chirp Pulse) allows a long pulsed radar to transmit a wide bandwidth waveform and achieve high resolution by means of pulse compression (cross correlation with a replica of the transmitted waveform). The signal shall be cross correlated at the output of the receiver to observe factors that affect sensitivity of the system to its resolution.

For targets to be well resolved or distinguished in a radar they need to be well separated before they provide meaningful results. The system's resolution here refer to how well can two or more targets be differentiated from each other. Theory for radar range resolution can be found in [?, pg 17].

3.7 ADC Considerations

The noise in the receiver chain must be well defined so that the quantisation noise in the ADC is below it (receiver noise) by correct amount. It is necessary that the Least Significant Bit (LSB) of an ADC is set to be approximately equal or above the noise level so that pulse integration can take place. Theory for this process can be found in [?, pgs (402-403)]. The minimum and maximum voltage of the ADC are -1 and 1 volts. This sets a voltage span of 2 volts peak-to-peak. The quantisation level of the ADC is therefore calculated as shown below assuming a 14 bit ADC.

$$V_q = \frac{2}{2^{14}}$$

$$= 0.00012207 \text{ [V]}$$

V_q is the ADC's quantisation voltage. In order for pulse integration to take place half of this voltage i.e. 0.000061035 [V] must be below the noise level in the receiver. This is done so that the probability of error in detection can be decreased as well [?, pg 84]. The correct input sampling rate into the ADC was achieved by decimating the previous sampling rate mentioned in section 3.2.3 by a factor of 355. This was done because the ADC is sampling at 210MHz and the Nyquist criteria must not be violated.

3.8 Pulse compression

In order to increase the signal to noise ratio a matched filter is applied to the signal so that the peak of the signal can be have a maximum peak . Theory for match filtering can be found in detail in[?, pg (431-435)]. The output at the transmission point was match filtered (cross-correlated) with the receiver output to obtain the peak signal-to-noise ratio in the radar receiver design. The peak value of the signal was calculated using matlab. The matlab code for match filtering is in **appendix A**. The process was carried out by reading the output values from System View and creating files were this data can be read. After storing data into files then signal processing was performed. From matlab the peak signal value and the standard deviation were calculated. The calculation that results in the peak signal-to-noise ratio. Table shows the values obtained.

Table 3.3: Matlab values in a pulse compressed signal

Signal Max Value [V]	STD [V]	SNR_{peak} [dB]
1.1767e ⁴	5.497e ³	3

3.9 Pulse integration

The Pulse Repetition Frequency (PRF) of the radar is to be 3kHz according to the terms of reference. The simulation achieve this PRF by sending pulses at a rate equal to the PRF. The output is then integrated to increase the signal to noise ratio.

3.10 Demodulation

The signal shall be demodulated digitally into I/Q components down to baseband at 50MHz. Modern radar receiver uses digital demodulation techniques [?]. This is done so as to alleviate problems presented by the conventional radar receiver demodulation technique. Conventional radar receiver uses two mixers which results in gain and phase mismatches and again it uses two ADC which also has mismatches. For the purpose of this report digital demodulation is employed. Figures 3.10 and 3.11 shows a block diagrams of the two radar receiver models. Digital demodulation is employed for the purpose of this report.

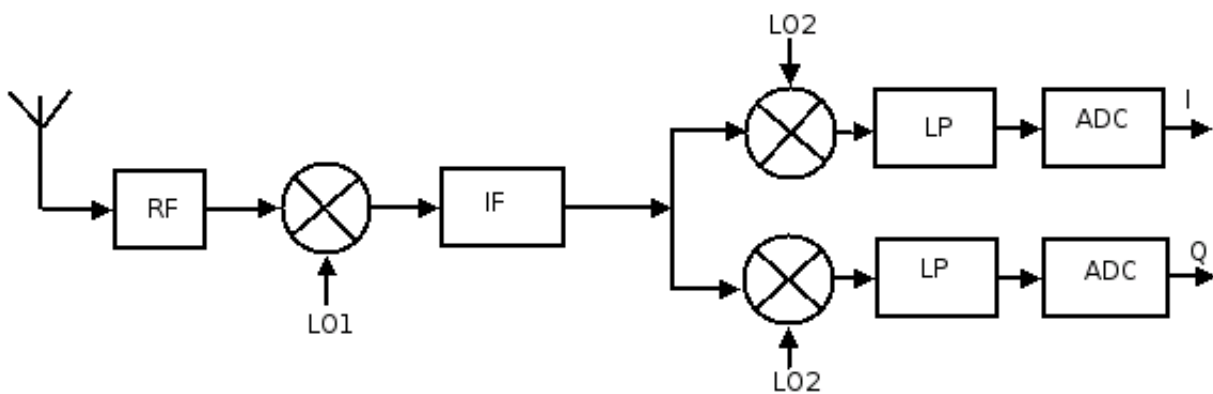

Figure 3.10: A block diagram of a conventional radar receiver demodulation

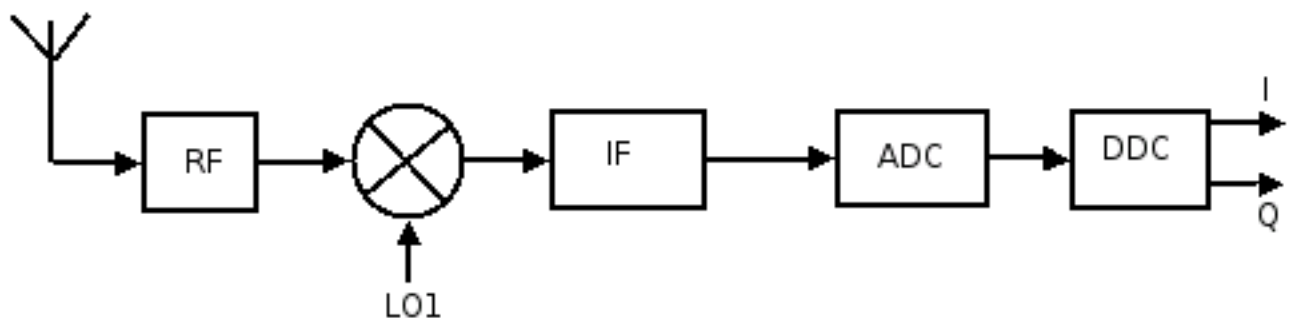

Figure 3.11: A block diagram of the modern radar receiver demodulation

3.11 Summary

The design of the Chirp Pulse radar simulation can be summarised as follows:

3.11.1 Transmitter

- Generation of the I and Q channels of the chirp baseband signal with real bandwidths of 50MHz each
- Two IF stages at 158MHz and 13000MHz for upconversion
- Final upconversion stage at RF of 93000MHZ
- 5th order Butterworth filter's were used for filtering purposes
- The calculation of noise figure in terms of signal-to-noise ratio to meet RF power for transmission
- The first and second filters have their bandwidth as mentioned in [?, pg 28] while the TWT's bandwidth was replaced by a 100MHz filter bandwidth.
- The transmission power of 3.5kW was arrived at by following design established in [?, pg 26]

3.11.2 Receiver

- The received signal is at RF frequency of 9300MHz
- The second downconversion stage is at 1300MHz
- The last downconversion is at 158MHz
- From last downconversion the signal is fed into an ADC with a 210MHz sample rate
- The receiver is tested with power returns from different targets found in [?]
- The design of the receiver is in such a way that power returns from targets will be used to simulate delays of the echoes at the receiver. This power returns are controlled through an attenuator to avoid exceeding ADC maximum power specifications or ADC dynamic range.
- The **LSB** of an ADC is set approximately to level of the noise level so that pulse integration can be carried out. The ADC's voltage quantisation level was calculated to be **122** micro-Volts while the receiver noise level is at **666** micro-Volts when no signal is coming.
- The receiver minimum signal-to-noise ratio was calculated using cascaded receiver noise figure given by equation 3.4 and a figure of 2dB was arrived at. The worst noise figure was calculated to be 6dB.
- The minimum detectable signal resulting from this receiver design is -95dBm. This was calculated by attenuating the input signal at the receiver and observing the level at which the signal just disappears into noise.



The theory of all RF components leading to noise generation and non-linearity was discussed so as to make test and observe how these components affect the sensitivity of the system's resolution. The transmitter and the receiver were both designed following designs already established in [?] and [?] . The requirements needed to operate the ADC such that we can obtain meaningful ADC output results were discussed. It was agreed with the project supervisor [?] at a later stage of the project that the propagation path or medium will be a single attenuator with no noise temperature for purposes of the simulation test. It was again agreed that the antenna gain must be set at 0dB and the antenna noise temperature must not be included in the simulation test. Demodulation of the signal down to baseband is performed digitally.

Chapter 4

Testing of the System

4.1 Introduction

At this point the simulation is tested to observe all the investigations to be carried out. Testing of the system here will be done by observing the system's impulse response at different outputs points. Theory of the radar shall be introduced for relevant later discussion of the test results in order to observe how the simulation compares with real SAR radar situation.

4.2 Filter Testing

Filter characteristics mentioned in section 3.4.2 are tested and observed. In particular a filter's group delay, the effect of the System's bandwidth vs the number of poles in a filter are checked.

4.2.1 Filter type

These filters used for testing are: 9th order Butterworth worth filter, 9th order Bessel filter and 9th order Chebyshev filter in comparison with the 5th order Butterworth filter. Figures show the group delays of these filters.

4.2.2 Test Procedure

The signal is observed at a output points when certain types of filters are inserted. The testing shall base comparison's of order of filter with the 5th order Butterworth filters as it was discussed in [?, pg 19] that this proves to have a good trade-off between bandwidth and group delay. The group delays at output points is observed.

4.2.3 Test Results

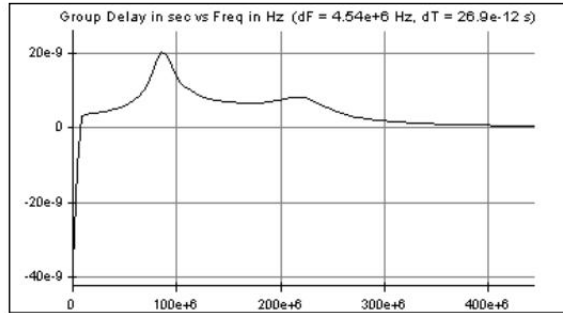

Figure 4.1: 5th order Butterworth filter group delay

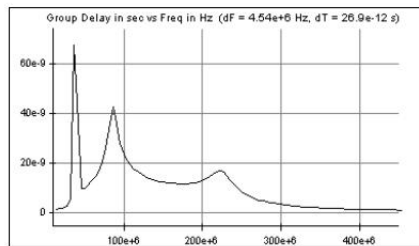

Figure 4.2: 9th order Butterworth filter group delay

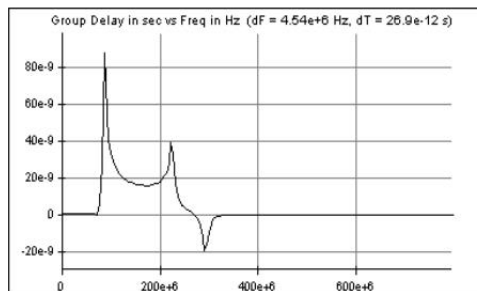

Figure 4.3: 9th order Chebyshev filter group delay

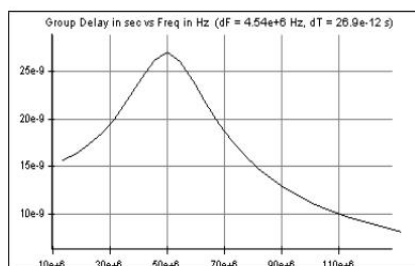

Figure 4.4: 9th order Bessel filter group delay

4.3 Non-Linearity Test

4.3.1 Test Procedures

The impulse response of the signal is observed at different output points so that any non-linearity in the components is observed. The output of the signal is also observed such that non-linearity already mentioned in section 3.5 can be observed. Figure 4.5 shows the mixer inter-modulation products.

4.3.2 Test Results

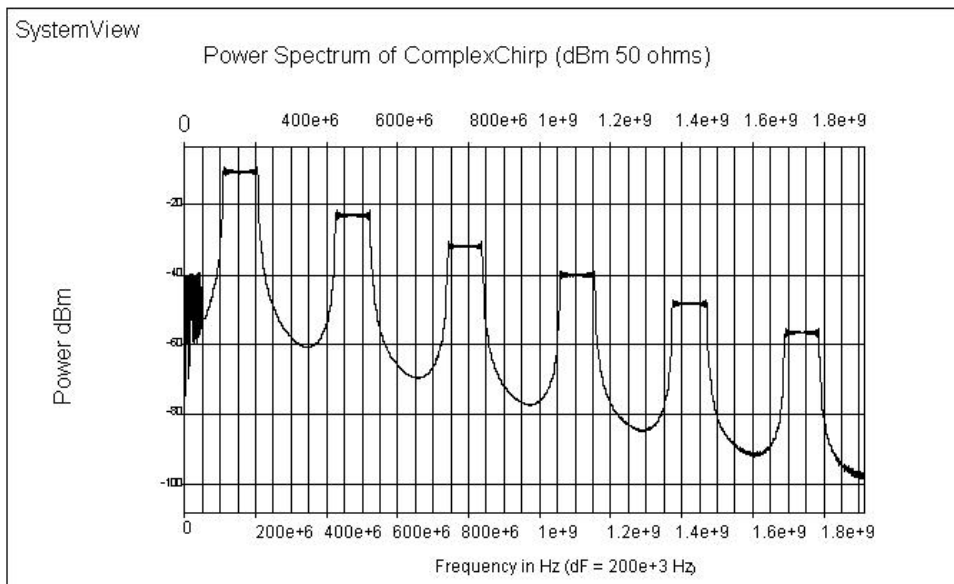

Figure 4.5: Mixer intermodulation products

4.4 Noise level test

4.4.1 Test Procedure

The system is made up of a chain of components and each components contributes noise. The noise figure of each component is defined and the is monitored at different outputs points in the transceiver chain .

4.4.2 Test Results

The results are shown in table 4.6.

Figure 4.6: Transmitter noise levels

Componet name and token number	Noise power level [dBm]
Mixer [1]	-115
Combiner [11]	-116
Attenuator [9]	-90
Amplifier [62]	1

4.5 Power Return Test

The power in the radar receiver is given by equation 4.1 below. For the purpose of the simulation all power levels are easily observed from System View. The gain of the receiver was calculated to be 64dB from the simulation so all theoretical application of the equation 4.1 below can be carried out using different targets power returns.

$$P_{RX} = \frac{P_{TX} G^2 \lambda^2 \sigma_t}{(4\pi)^3 R^4 L_S} \quad [W] \quad (4.1)$$

P_{RX} is the power at the receiver while P_{TX} is the transmitted peak power. In this simulation the transmitted peak power is 3.5kW. The gain G here refers to the duplex antenna gain which has the same transmitter and receiver gains. L_S is the medium or path loss simulated, σ_t is the radar cross sectional area of the target approximated by maximum attenuation in the simulation propagation path loss and R is the range or distance to the target approximated by taking cross-sectional area of the target closest to the maximum attenuation.

4.5.1 Test procedures

At this stage the signal is tested using different down profile ranges i.e. echoes or power returns from targets used in [?, pgs (28-32)]. Table 4.1 tabulate the ground range profile. The near, middle and far swath targets were used. To achieve this power returns the signal was attenuated to simulate the path or propagation losses. The attenuation was done using an electronic attenuator in System View. The delays to the targets were also simulated using System View. The delays for each target were calculated using equation 4.2 found in [?, pg 14].

$$R = \frac{c\tau_d}{2} \quad [m] \quad (4.2)$$

R is the range to the target while c is the speed of light with a value of 299792458 [m/s] and τ_d is the two delay time to the target.

Table 4.1: The ground range profile used for testing performance of the designed radar

Target	Range [m]	Return power [dBm]	Attenuation on simulation [dB]	Delays
Near swath	3000	-90	125	20 [μs]
middle swath	4000	-100	135	267 [μs]
far swath	3000	-85	120	20 [μs]

Table 4.7 below show the Power Budget for the corner reflector used in [?, pg 29].

Figure 4.7: Power Budget for Corner Reflector

P_{tx}	65.44	[dBm]
G^2	49.4	[dB]
λ^2	-29.8	[dBm ²]
σ_t	43.1	[dBm ²]
$(4\pi)^3$	-33	[dB]
R^4	-139	[dBm ⁴]
L_s	-10	[dB]
P_{rx}	-53.86	[dBm]

An attenuation of 95 [dB] in the simulation was carried out in order to match the return power from a corner reflector.

4.5.2 Test Results

The results from four targets used for testing are shown in table 4.3 .

Table 4.2: Results obtained by testing the simulation with near, middle, far swath and corner reflector targets

Target	input power [dBm]	output power [dBm]
Near Swath	-90	20
Middle swath	-105	8
Far swath	-85	23
Corner Reflector	-53.86	25

4.6 Radar Resolution

Radar resolution here refers to how well can targets be recognised even if they are very close to each other as mentioned in section 3.6. The equation 4.3 below shows a theoretical calculation of the radar resolution. The separation between the pulses must be greater than the pulse length so that they can be resolved to give meaningful results [?, pg 17].

$$R_r = \frac{c\tau}{2} \quad [\text{m}] \quad (4.3)$$

R_r [m] is the range resolution while c is the speed of light with its value given as 299792458 [m/s] and τ is the period of the pulse. The calculation of range resolution from these factor yields a value of **750** [m]. In order to meet the Nyquist criteria in sampling the bandwidth B_p of the pulse must be sampled at a rate atleast equal to B_p at the receiver output [?, pg (396-397)]. For a slant range resolution R_s of 1.5[m] obtained by equation 4.4 the bandwidth B_p is given by equation shown below where B is the bandwidth of the system. This is the slant range range resolution of this radar simulation. The calculation of the range resolution was done by observing the 3dB bandwidth (0.707 of the maximum voltage) range of the compressed pulse.

$$R_s = \frac{c}{2B} \quad [\text{m}] \quad (4.4)$$

$$1.5 = \frac{c}{2B_p}$$

$$= 100[\text{MHz}]$$

The maximum range to the target that this radar simulation design can handle is calculated from the knowledge of the minimum signal to noise ratio obtained in chapter 3 section 3.4. Equation 4.5 shows how the maximum range is calculated. This equation is found in [?, pg 13]

$$R_{max} = \left(\frac{P_{tx} G_t G_r \sigma \lambda^2 L_s}{(4\pi)^3 N(SNR)} \right)^{1/4} \quad [\text{m}] \quad (4.5)$$

The noise power used is the receiver output noise power. R_{max} is the maximum range P_{tx} is the transmitted power and G_t and G_r are transmitter and receiver antenna gains. λ is the wavelength of the transmitted signal and L_s is the path or medium propagation losses and lastly σ is the radar cross sectional area of the target. It was agreed that the antenna gains is 0dB. The wavelength is

calculated by taking the transmitting frequency at 9.3GHz. The radar cross-sectional area of the target is approximated by choosing the cross-sectional area closest to the maximum attenuation in the simulation path loss. From parameters in table the maximum range obtained is 1153 [m].

4.7 Summary

Testing of the system was done following the terms of reference. These tests in particular were carried out

- Filter testing for investigation of trade-off between group delay and system bandwidth
- Losses testing for observation of component limitations on the radar system
- Non-linearity of the system for testing and observing component contribution towards non-linearity
- Power return test for important comparisons of radar theory.

4.8 Discussion and Analysis

4.8.1 Filter test Results

In filters the pulse length signal increases as the number poles in a filter increases [?, pg 19]. This is undesirable effect because it causes the pulse envelope to vary from input to output causing a phenomena known as group delay. The phenomena of group delay has a negative impact on the resolution of the radar. The front end bandwidths of both the transmitter and the receiver were made larger than the system bandwidth to avoid group delay. Figure 5.6 below illustrates the pulse outputs of different filters. Fifth order filter as mentioned proves to have a good trade-off between group delay and bandwidth. Figure 5.6 suggests that the fifth order Butterworth filter has better properties.

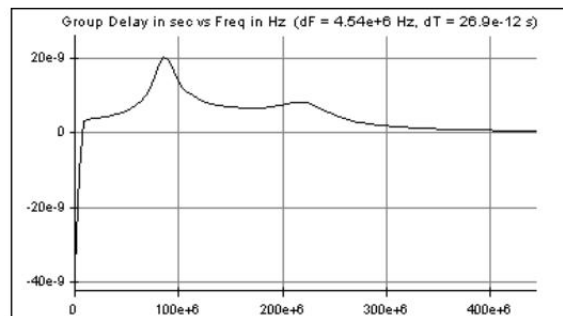

Figure 4.8: 5th order Butterworth filter group delay

The filter proves that in our band of interest group delay is small. Increasing the number of poles results in filters generating undesirable group delays. This can be observed properly in Chebyshev and Bessel filters.

4.8.2 Non-linearity

Inter-modulation products introduced by the mixer contributes towards non-linearity. The image frequencies appearing in the mixer outputs require filtering. A front end bandpass filter with a bandwidth of 140Mhz was used in the transmitter to avoid sharp roll-off since sharp roll-off require an increase in number of poles, hence group delay. Figure 4.9 below shows the mixer harmonics. The choice of this mixer was according to the specifications as mentioned in [?].

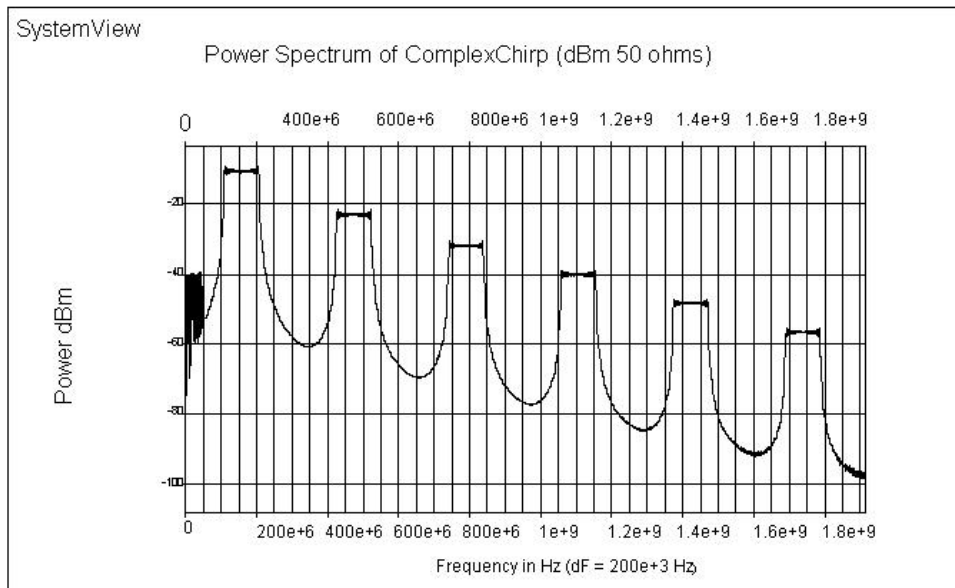

Figure 4.9: Mixer harmonics showing non-linearity contribution

The mixer harmonic intermodulation products impact negatively on the resolution of the radar. The image frequencies are indistinguishable from the real wanted image since by fourier theory every real signal has negative and positive frequencies components similar in magnitude [?, pg 26]. These harmonics also put a lot of stress on the subsequent filtering i.e. sharper filters will be required and hence group delay. Amplifier intercept points setting are important in avoiding non-linearity. If this is not done the signal saturates the analog components. Local oscillators operating at the high power than the mixer requires generates local oscillator feed-through.

4.9 Power return test

It can be seen from figure 4.3 that an increase in gain of the system has resulted in big signals at the output of the receiver. The MGC and STC implemented in the receiver design ensures that the RF components do not run into saturation. An electronic attenuator used in the simulation used in the simulation makes it easy to simulate power returns from targets. **The noise figure of this design system was below the noise figure of the original design by 0.47 dB.**

Table 4.3: Results obtained by testing the simulation with near, middle, far swath and corner reflector targets

Target	input power [dBm]	output power [dBm]
Near Swath	-90	20
Middle swath	-105	8
Far swath	-85	23
Corner Reflector	-53.86	25

The calculation of the maximum range is found by approximating the 3 dB bandwidth power of the receiver. The equation 4.5 was not used because the cross-sectional area of the target was not known. The results of power return simulations shows that we can determine the maximum range of the target by attenuating the signal to a level were it is just below noise level and even achieve the maximum range through match filtering process.

4.10 Demodulation and Pulse Integration

The digital demodulation of the signal was supposed to be carried out to bring the signal down to base band. It was agreed upon with the project supervisor that if time permit the signal will be demodulated digitally and integrated to improve the signal-to-noise ratio.

Chapter 5

Conclusions and Recommendations

5.1 Conclusions

Based on the discussion and analysis of the results the following conclusions are drawn:

- An attenuation of 130 [dB] sets the minimum detectable signal
- Fifth order butterworth filters indeed have a good trade-off between group delay and bandwidth
- Mixer harmonic intermodulation products put stress on filtering requirements
- The Receiver signal to noise ratio is satisfactory
- A gain of 77.5 [dB] set the receiver to detect even smaller signals
- Tailoring the system bandwidth give good results of signal envelope from input to output
- Digital demodulation and pulse integration were not carried out due to time constraints
- Chirp Radar signal was satisfactory after making sure that the correct power levels were met
- MGC and STC used controlled the gain of the transmitter well
- The stage of demodulating the signal to find the impulse response as a function of time has not been reached

5.2 Recommendations

The following recommendations are made based on the discussions and conclusions made:

- In setting the minimum detectable signal the correct attenuations must be set by considering the ADC operation
- 5th Butterworth filters must be used to achieve good trade-off between group delay and bandwidth in order to reserve the radar resolution
- Good care must be taken to operate RF components according to their specifications
- The receiver design must ensure good trade-off between a high gain can to compensate for path losses and care for not saturating RF components
- Pulse integration (stacking) of the output must be done to improve the signal to noise ratio
- Demodulating the signal down to baseband will help in getting the impulse response as a function of time

Appendix A

Matlab Match Filter code

```
addpath('H:\projects_undergrad\2004\SASSIM\simulation')
addpath('H:\projects_undergrad\2004\SASSIM\MatlabChirpCode')
v_tx = importdata('v_tx.txt');
v_rx = importdata('v_rx.txt');
% Setting up parameters for the chirp pulse
c = 299792458;      %Speed of light;
B = 100e6;         %Bandwidth of each I and Q
Fs = 210e6;       %The sampling frequency
dt = 1/Fs;        %Sample spacing
r_max = 11513 ;   %Chirp Radar maximum Range
t_max = 2*r_max/c; %Time delay to max Range
%Time vector for time values of samples
%t = 0:dt:t_max; %Vector for range values
r = c*t/2;
%Start of chirp code
T = 5e-6;
fo = 158e6;
K = (B/T);
td = T;
plot(t,v_tx)
V_TX = fft(v_tx);
V_RX = fft(v_rx);
figure;plot(abs(V_TX),'r')
figure;plot(abs(V_RX),'b')
H = conj(V_TX);      %Conjugation for match filtering
V_MF = H.*V_RX;     %Match filtering in frequency domain
v_mf = ifft(V_MF);  %Time domain match filtered signal
display(max(v_mf))
```



```
display(std(v_mf))
figure;plot(real(v_mf))
%Forming analytic signal
V_ANAL = V_MF;           %cancelling negative frequencies
v_anal = ifft(V_ANAL);
figure;
plot(r,abs(v_anal))
```

Appendix B

Simulation Figures

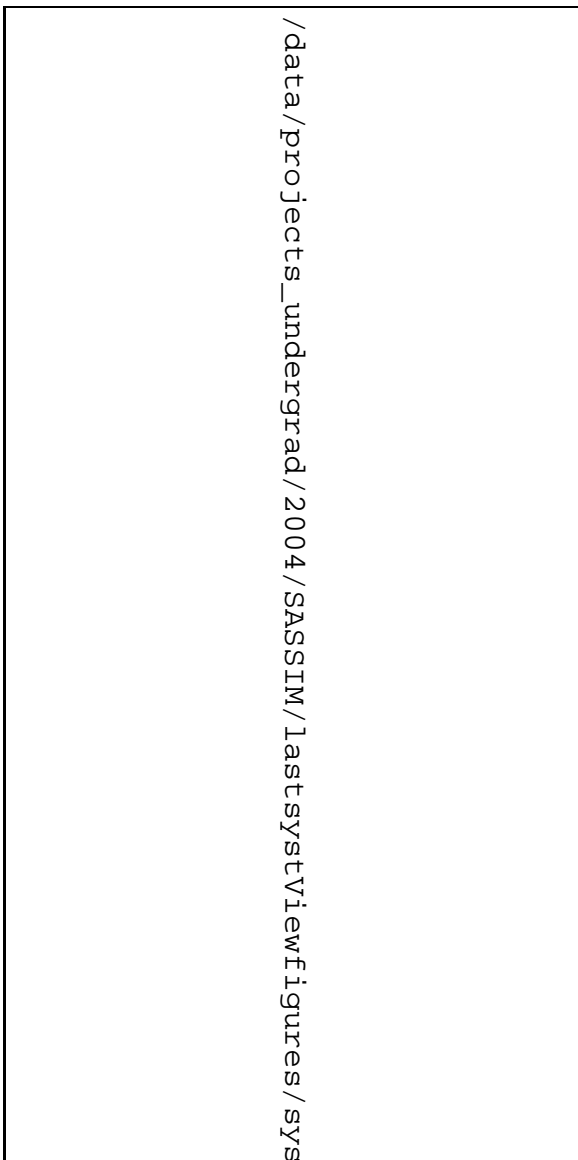

Figure 5.1: The transmitter System View set-up

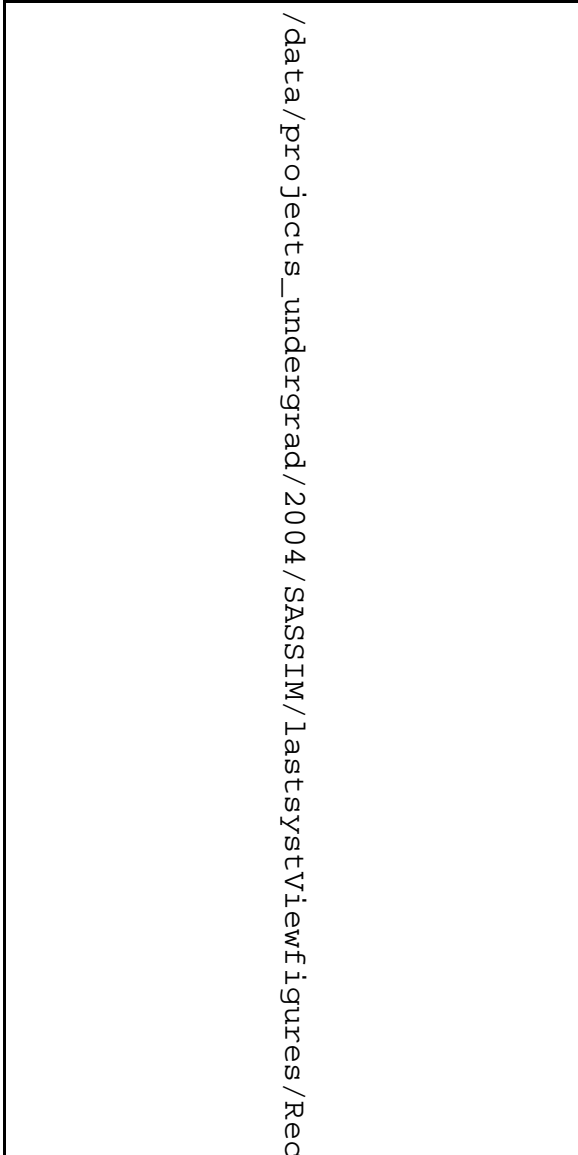

Figure 5.2: First section of the receiver System View set-up

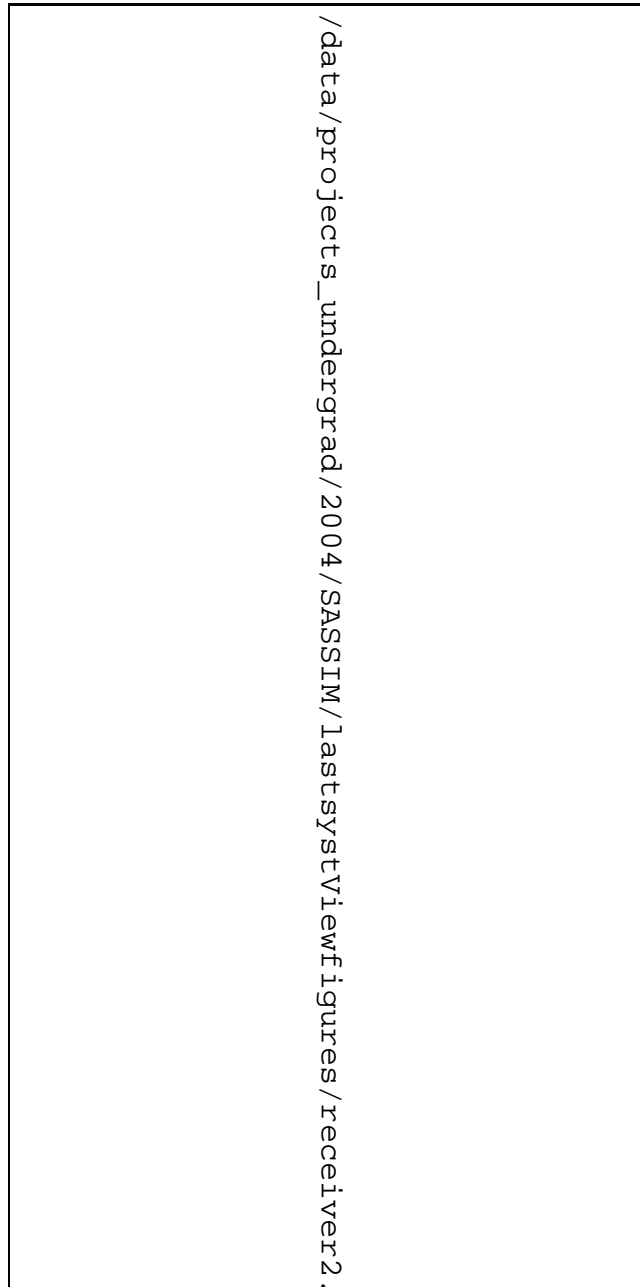

Figure 5.3: Section of the receiver System View set-up

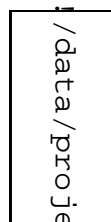

Figure 5.4: Output from receiver to the ADC

Simulation Plots

/data/projects/undergrad/2004/S

Figure 5.5: The signal at the transmission point

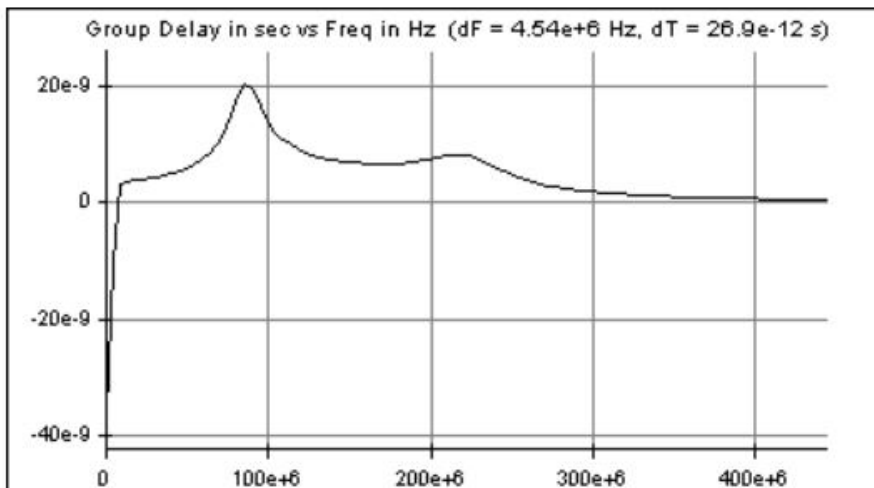

Figure 5.6: 5th order Butterworth filter group delay

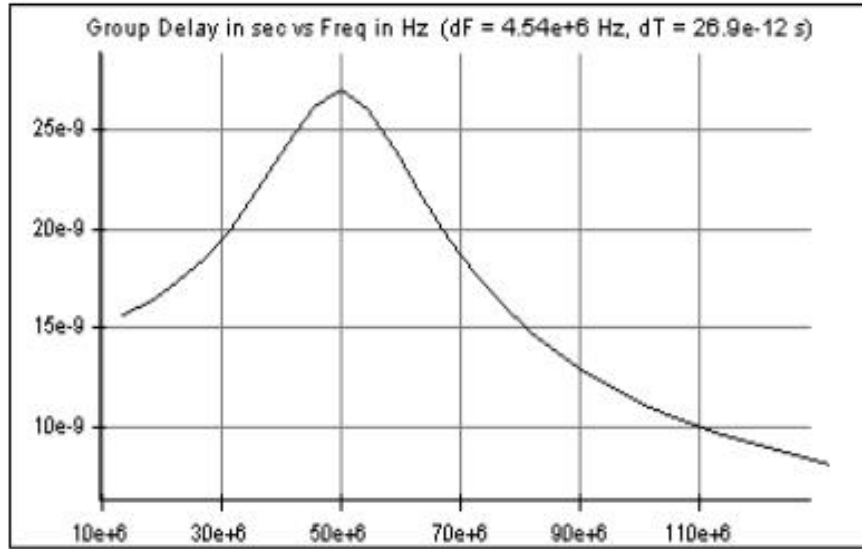

Figure 5.7: 9th order Bessel filter group delay

The vertical axis in figure ?? represents power in dBm while the horizontal axis represent frequency in hertz [Hz].

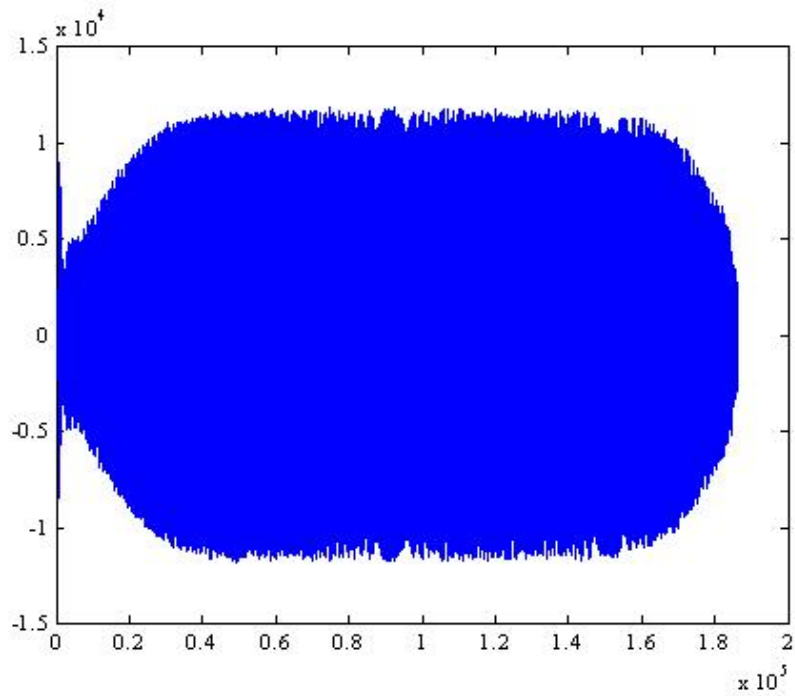

Figure 5.8: The real match filtered signal

/data/projects/undergrad/2

Figure 5.9: Analytic Signal

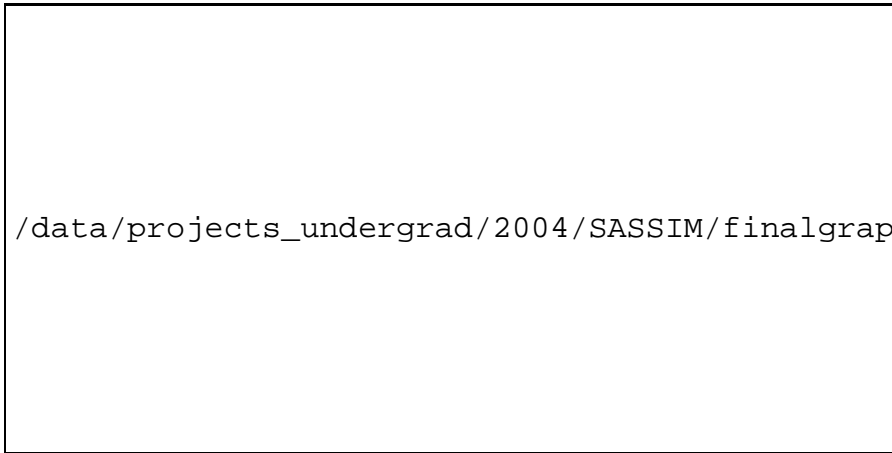

Figure 5.10: Matlab version of the signal at 2nd IF output

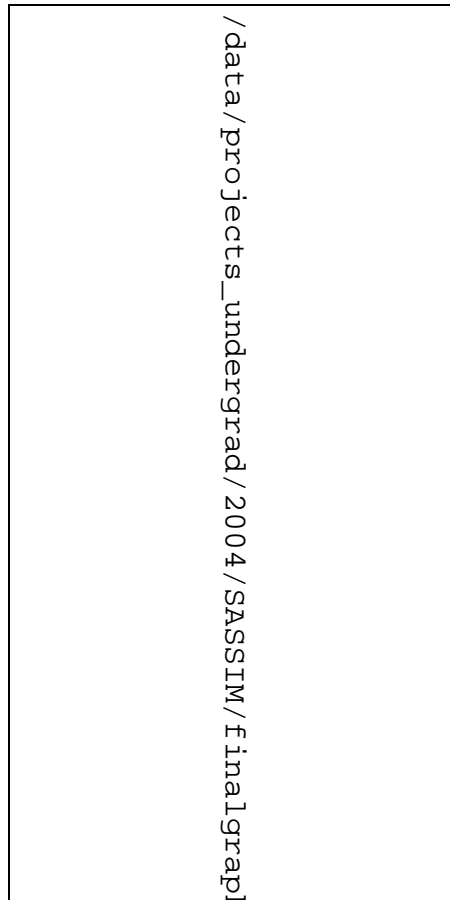
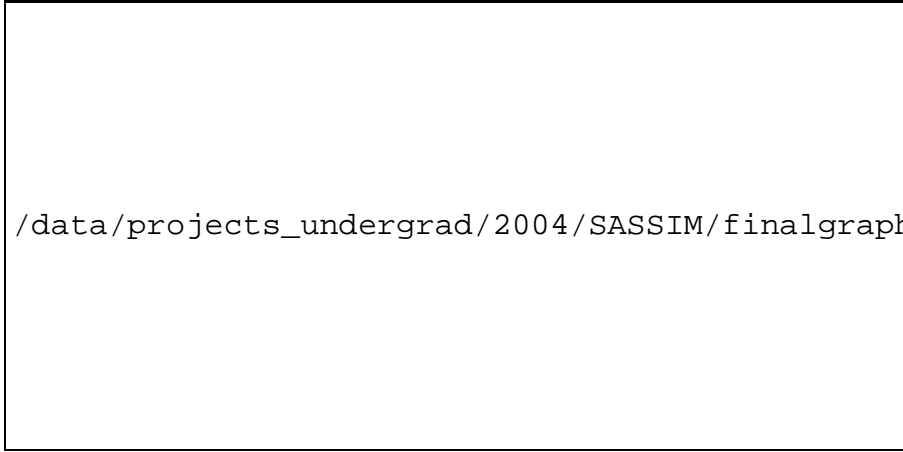

Figure 5.11: Matlab output of the receiver at 158MHz



/data/projects_undergrad/2004/SASSIM/finalgraphics/matchfiltered

Figure 5.12: The match filter output



Bibliography